

This is what makes our pumps unique

ELECTRIC DRAINAGE PUMPS

MINEX – MINETTE – MINOR – MAJOR – MASTER – MATADOR

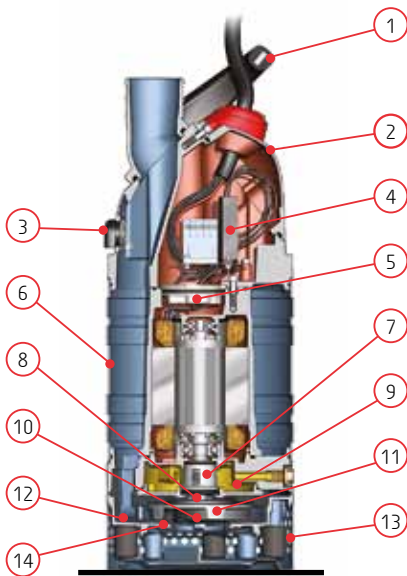

1. **Ergonomic handle with a rubber grip on a metal frame**
Larger pumps can be placed upside down during service
New! Lifting eyelet for hooks (Minor – Major, Senior – Sandy)
2. **Inspection cover for easy access to junction box**
New! Larger opening simplifies maintenance
New! Simplified disassembly/assembly of the pump and reduced risk of leakage due to integrated intermediate-piece
3. **Air valve cools the pump when water is pumped**
New! Improved cooling performance thanks to better flowing air valves
4. **SMART motor protection protects the pump against electrical problems and built-in contactor eliminates need for external starting equipment (Minex – Matador and Salvador – Sandy)**
Temperature switch cuts the power if the temperature gets too high
Phase guard protects the pump by cutting the power if a phase fails
Grindex Rotasense guard ensures the impeller turns in the right direction
5. **Enhanced terminal board with sealing function**
New! Quick-release terminal plate unit simplifies maintenance and acts as an effective seal between the junction box and the stator
6. **Durable outer jacket made from corrugated stainless steel**
Provides high resistance against harsh conditions and rough handling
7. **Cartridge seal for easier servicing**
Pre-assembled in a single unit - faster and easier to service
New! Newly constructed seal design with rugged metal housing for improved heat transfer and improved sealing function for longer life

ELECTRIC SUBMERSIBLE SLUDGE PUMP

SALVADOR – SENIOR – SANDY

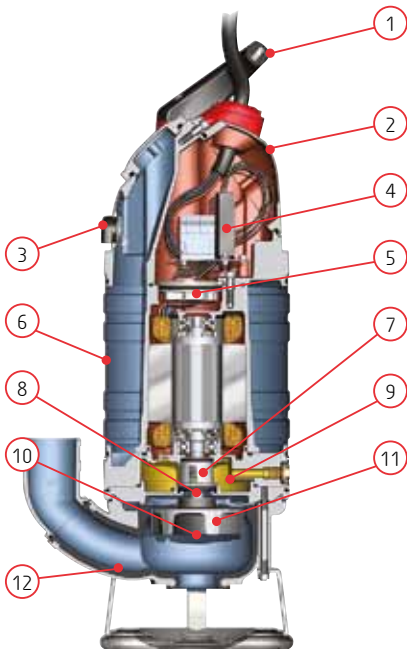

8. **Built-in particle repeller**
The particle repeller carries particles away from the seal, thereby reducing wear and increasing the life of the seal
9. **Simplified oil inspection and service, thanks to external oil plugs**
New! Larger oil capacity improves cooling and increases seal life (Minex, Minette, Salvador, Matador)
10. **Single adjustment screw for easy adjustment of the impeller and better performance**
New! New construction that minimizes the risk of improper adjustment (Minex, Minette)
11. **Hard-Iron™ impeller**
New! New design of the open impeller - increases durability and performance (Minex – Minette)
12. **Hard wearing coating of polyurethane on sludge pumps**
Better durability in some of the most demanding applications
New! Minor – Matador pumps are available with Polyurethane coated options
13. **Durable strainer in stainless steel with ergonomic grip**
Easy to clean and keeps the inlet free of debris
New! Deeper edge provides more stability and better grip for lifting
14. **Wear Protection system for drainage pumps**
Wear protection increases the life of hydraulic parts by transporting particles away from the adjustment gap