

Electric pump

EL200

PUMP SPECIFICATIONS	Mod. A	Mod. B
Capacity [m ³ /h - (USGPM)]	350 - (1540)	450 - (1980)
Head [m - (ft)]	48 - (156)	44 - (142)
Impeller diameter [mm - (in)]/type	495 - (20)/3 blades closed	
Flanged bore size [DN.../PN... - (in)]	DN200/PN10 - (8)	DN250/PN16 - (10)
Cross section diameter [mm - (in)]	60 - (2.4)	
Weight (without cable) [kg - (lbs)]	2900 - (6380)	2950 - (6490)

ELECTRIC MOTOR	
Power [kW-HP]	150-200
Voltage [V]/Current [A]	460/235
Phases/Poles/Frequency [Hz]	3/6/60
Speed [RPM]	1180
Insulation class	H
Power cable 20m (IEC 60245- 4)	H07RN-F 4G95

MATERIALS	
Casing	Spheroidal cast iron EN-GJS-500-7 (EN 1563)
Motor housing	Cast iron EN-GJL-250 (EN 1561)
Wear parts	High chrome EN-GJN-HV600 (XCr18) (EN 12513)
Main shaft	High tensile steel 39NiCrMo3 (AISI 9840)

SEALS / LUBRICANT	
Motor side seals	1 mechanical seal (silicon carbide in oil bath)
Impeller side seals	1 mechanical seal (silicon carbide in oil bath) + 2 lip seal (1 BUNA + 1 TPU)
Oil type	ISO 320

DIMENSIONS [mm - (in)]							
H	W	D	F	H1	A	B	C
2150	1260	1080	765	1800	500	590	520
(86)	(50.4)	(43.2)	(30.6)	(72)	(20)	(23.6)	(20.8)

PERFORMANCE CURVES

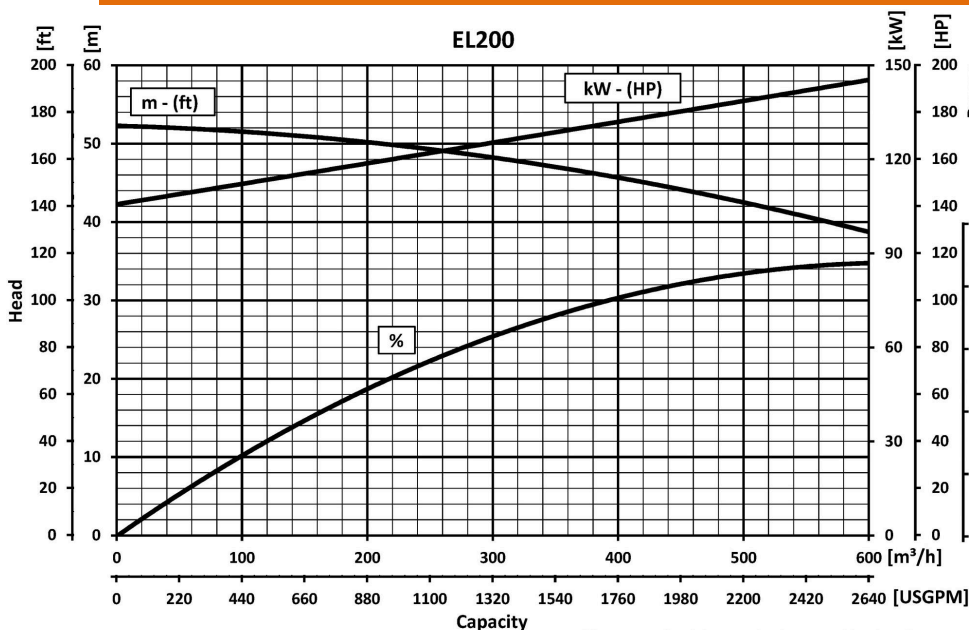

We reserve the right to make changes without notice

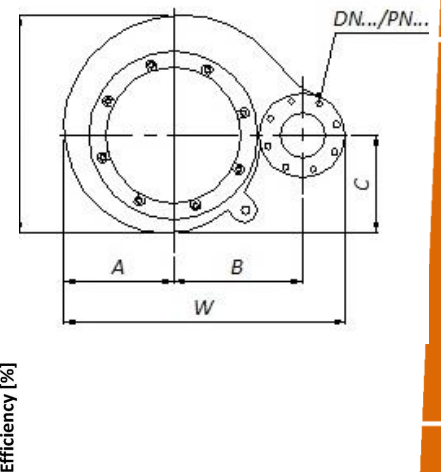
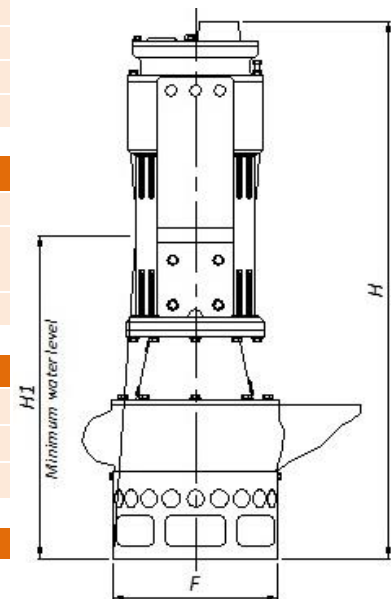

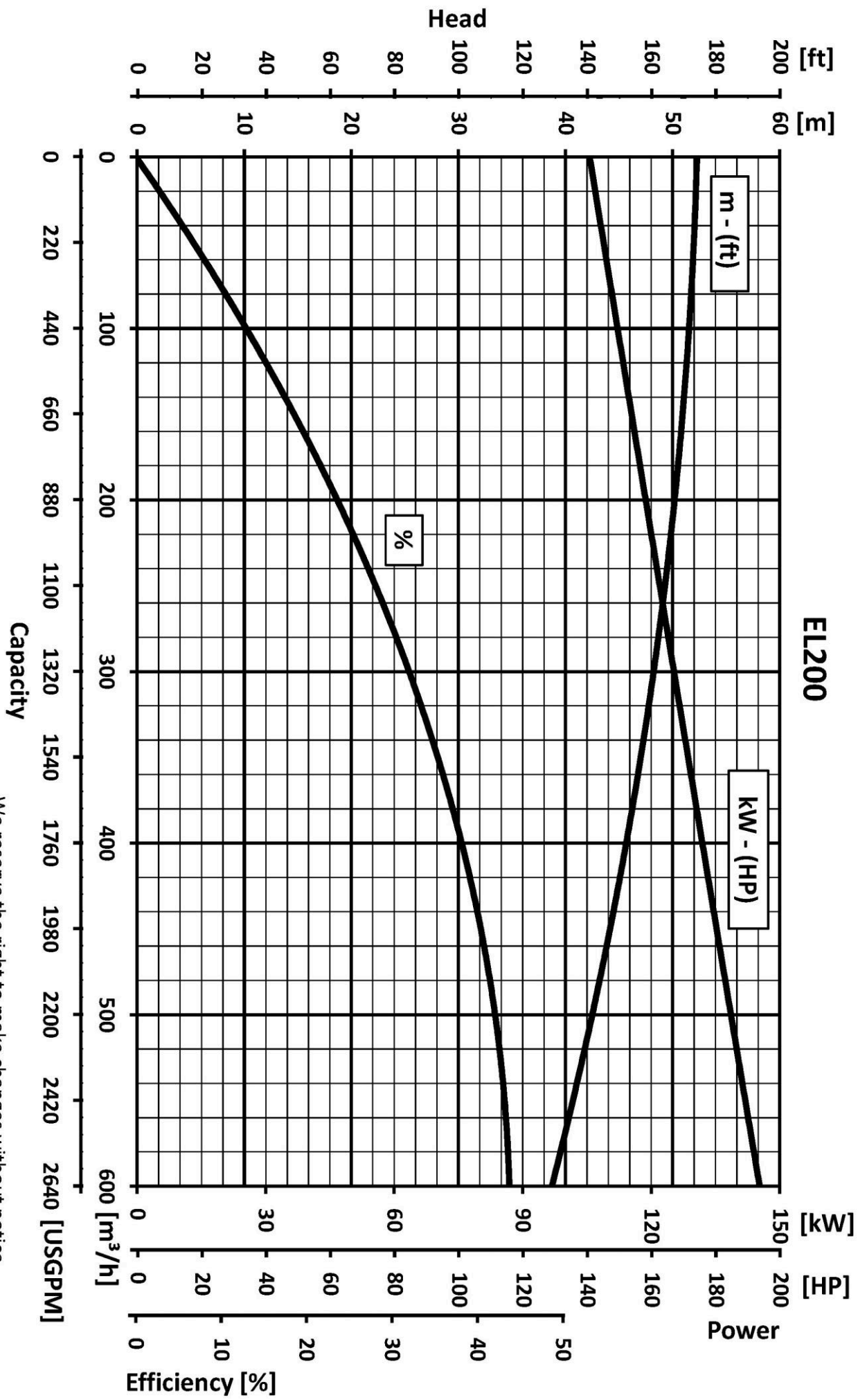

We reserve the right to make changes without notice