

Electric pump

EL606S

PUMP SPECIFICATIONS	Mod. A	Mod. B
Capacity [m ³ /h - (USGPM)]	240 - (1056)	420 - (1850)
Head [m - (ft)]	38 - (124)	30 - (98)
Impeller diameter [mm - (in)]/type	440 - (17.6)/3 blades closed	
Flanged bore size [DN.../PN... - (in)]	DN150/PN10 - (6)	DN200/PN10 - (8)
Cross section diameter [mm - (in)]	60 - (2.4)	
Weight (without cable) [kg - (lbs)]	1200 - (2640)	1250 - (2750)

ELECTRIC MOTOR	
Power [kW-HP]	90-120
Voltage [V]/Current [A]	460/149
Phases/Poles/Frequency [Hz]	3/6/60
Speed [RPM]	1180
Insulation class	H
Power cable 20m (IEC 60245- 4)	H07RN-F 4G50

MATERIALS	
Casing	Spheroidal cast iron EN-GJS-500-7 (EN 1563)
Motor housing	Cast iron EN-GJL-250 (EN 1561)
Wear parts	High chrome EN-GJN-HV600 (XCr18) (EN 12513)
Main shaft	High tensile steel 39NiCrMo3 (AISI 9840)

SEALS / LUBRICANT	
Motor side seals	2 lip seals (BUNA)
Impeller side seals	5 lip seals (3 BUNA + 2 PTFE) + 1 V-RING (TPU)
Oil type	ISO 320

DIMENSIONS [mm - (in)]							
H	W	D	F	H1	A	B	C
1610	935	725	545	1055	365	430	325
(64.4)	(37.4)	(29)	(21.8)	(42.2)	(14.6)	(17.2)	(13)

PERFORMANCE CURVES

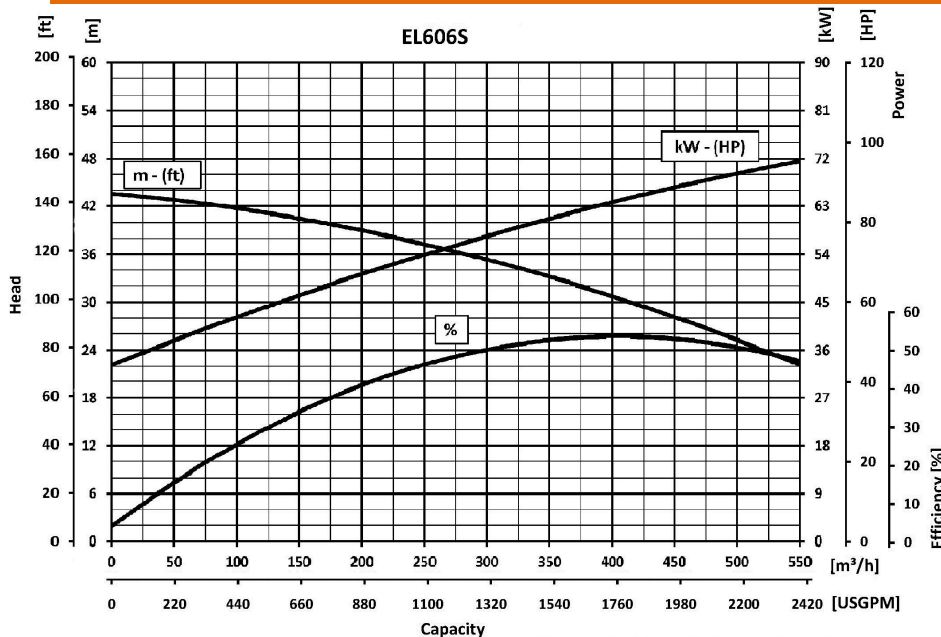

We reserve the right to make changes without notice

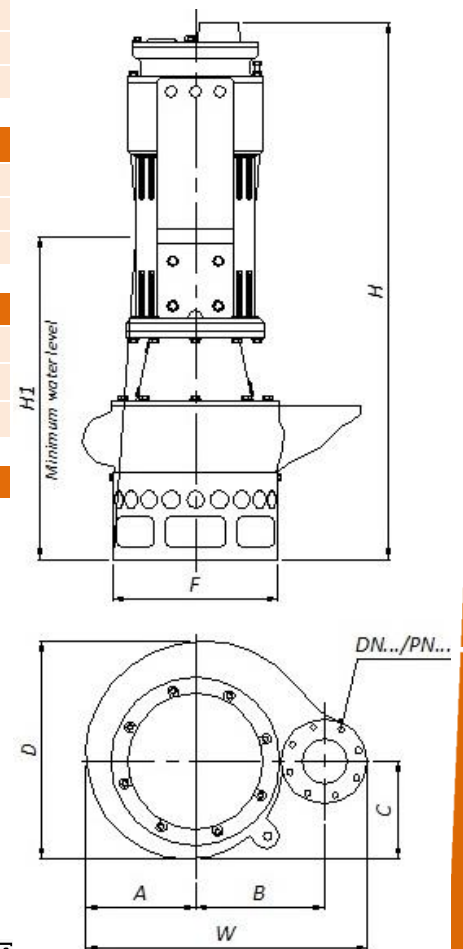

EL606S

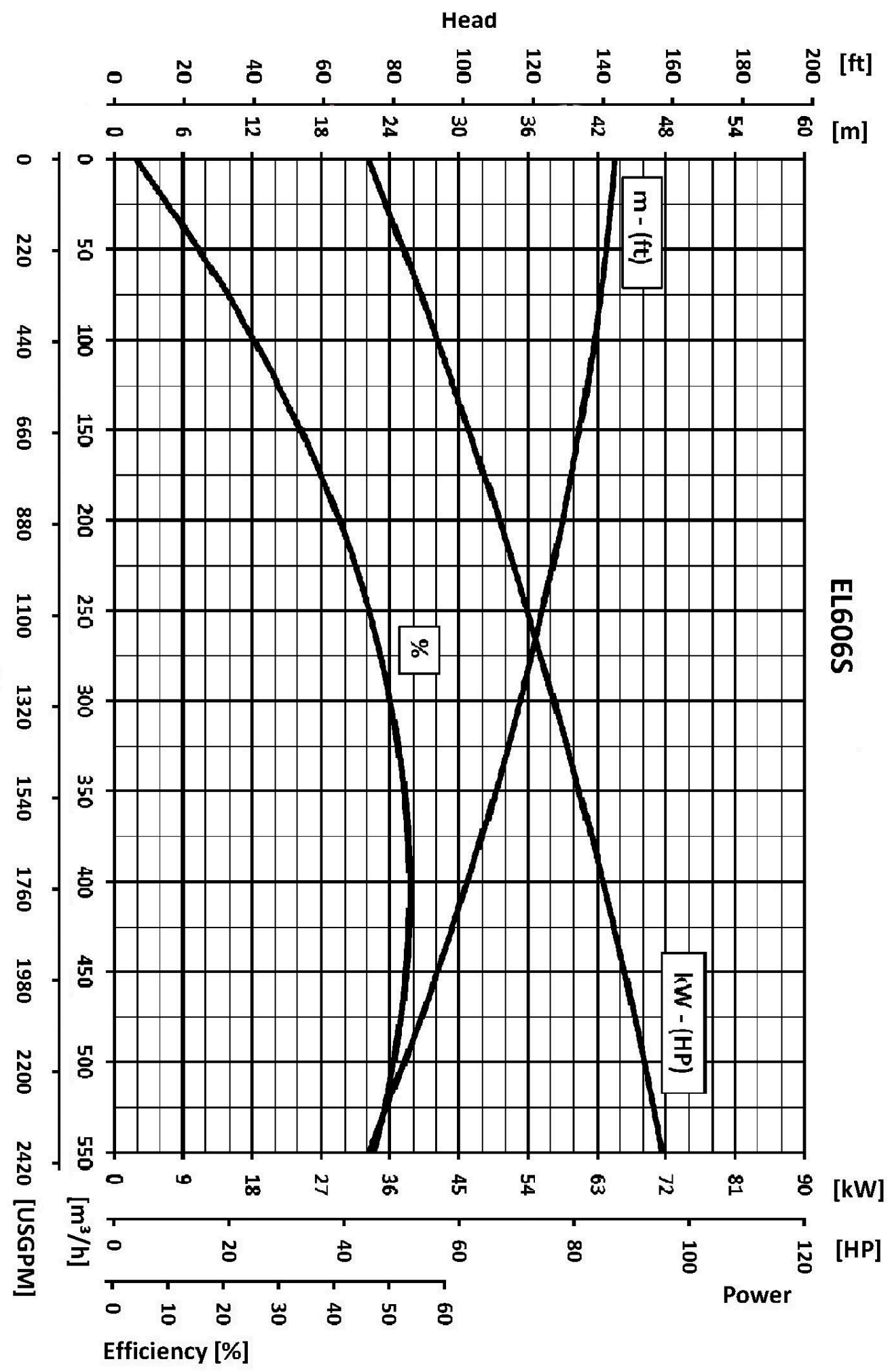

We reserve the right to make changes without notice