

Hydraulic pump

HY35

PUMP SPECIFICATIONS

Max Capacity [m ³ /h]	200
Max Head [m]	40
Impeller diameter [mm]/type	435 /2 blades closed
Flanged bore size [DN/PN]	DN100/PN10
Solid handling [mm]	35
Weight [kg]	500

HYDRAULIC MOTOR

Motor displacement [cc]	55
Max. oil flow rate[l/min]	65
Max. pressure [bar]	300
Power [kW-HP]	33 - 40
Speed [RPM]	1180

MATERIALS

Casing	Spheroidal cast iron EN-GJS500-7 (EN1563)
Motor housing	Cast iron EN-GJL-250 (EN 1561)
Wear parts	High chrome EN-GJN-HV600 (XCr18) (EN12513)
Main shaft	High tensile steel 39NiCroMo3 (AISI 9840)

SEALS / LUBRICANT

Motor side seals	2 lip seals (BUNA)
Impeller side seals	5 lip seals (3 BUNA + 2PTFE) + 1 V-ring (TPU)
Oil type	ISO 32

DIMENSIONS [mm]

H	W	D	F	H1	A	B	C
1210	818	667	540	270	327	380	323

PERFORMANCE CURVES

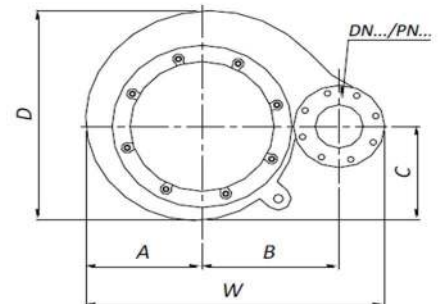
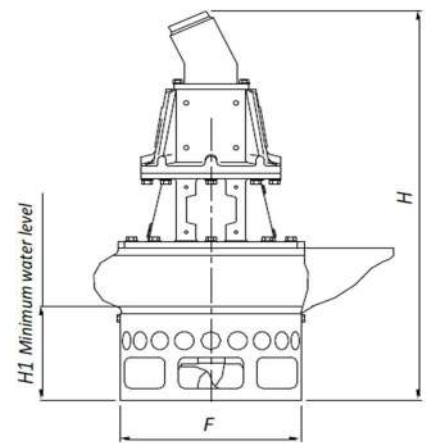
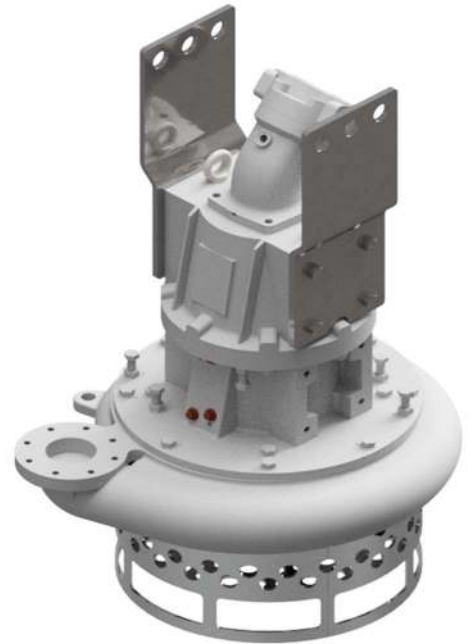
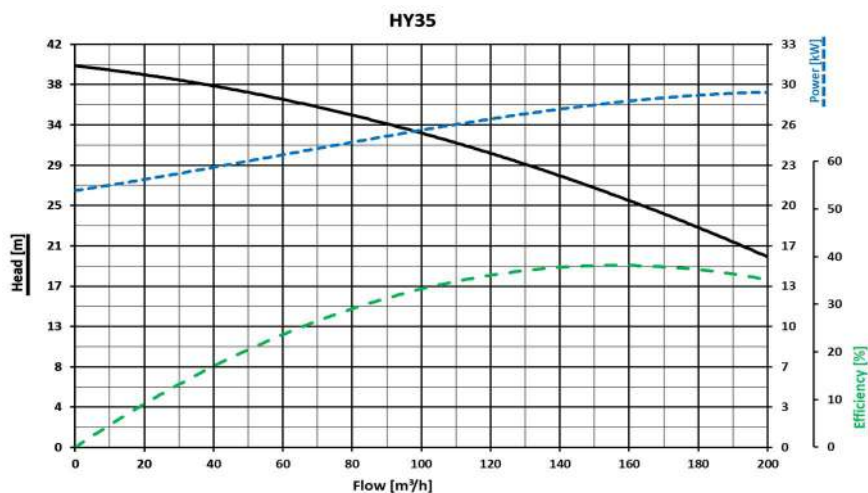

HY35

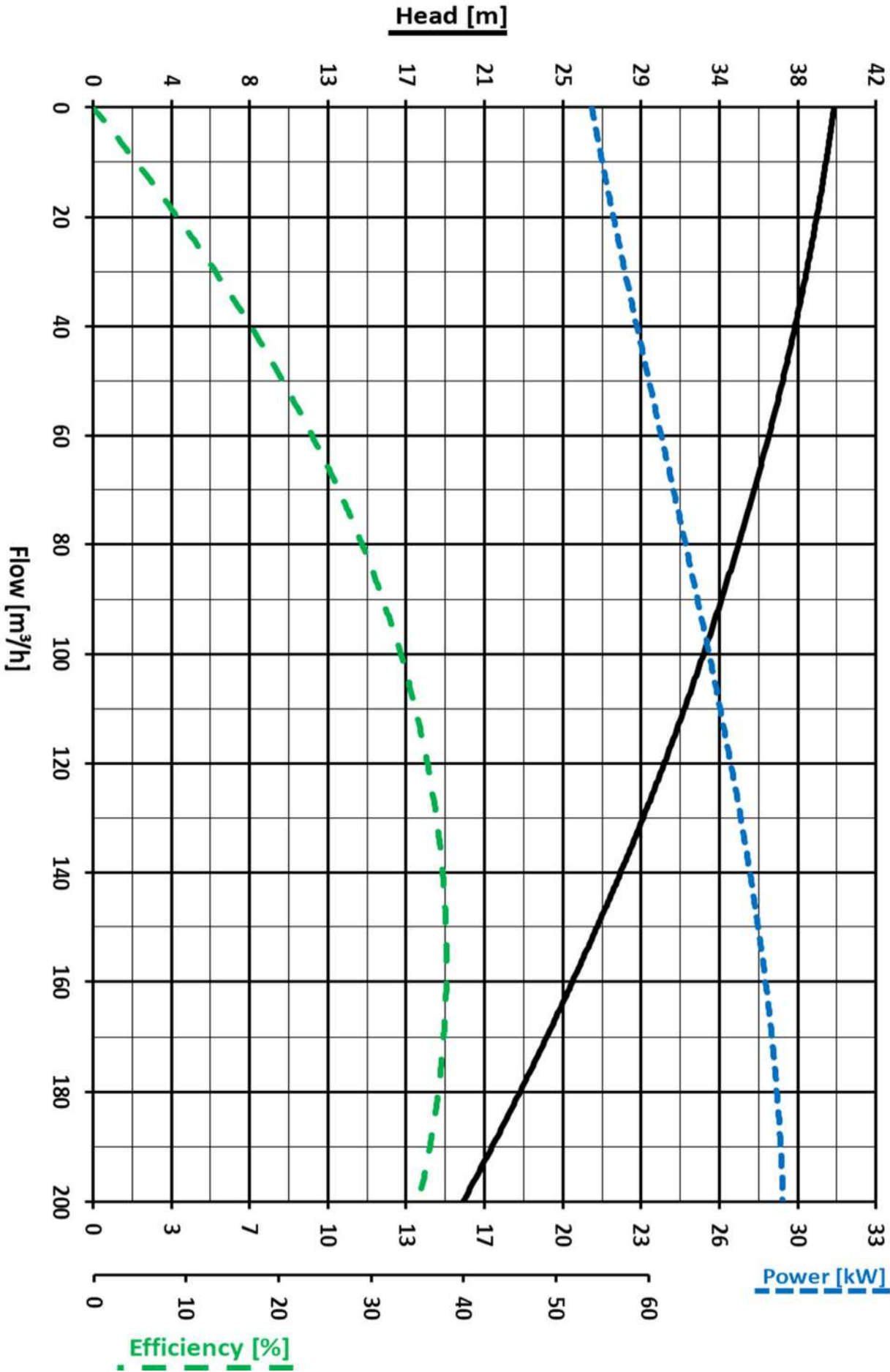

We reserve the right to make changes without notice