

# Hydraulic pump

## HY50HC

### PUMP SPECIFICATIONS

Capacity [m <sup>3</sup> /h]	250
Head [m]	22
Impeller diameter [mm]/type	380/2 blades closed
Flanged bore size [DN.../PN...]	DN150/PN10
Cross section diameter [mm]	60
Weight [kg]	700

### HYDRAULIC MOTOR

Motor displacement [cc]	75
Max. oil flow rate [l/min]	90
Max. pressure [bar]	300
Power [kW-HP]	45-60
Speed [RPM]	1180

### MATERIALS

Casing	Spheroidal cast iron EN-GJS-500-7 (EN 1563)
Motor housing	Cast iron EN-GJL-250 (EN 1561)
Wear parts	High chrome EN-GJN-HV600 (XCr18) (EN 12513)
Main shaft	High tensile steel 39NiCrMo3 (AISI 9840)

### SEALS / LUBRICANT

Motor side seals	2 lip seals (BUNA)
Impeller side seals	3 lip seals (BUNA) + 1 V-RING (TPU)
Oil type	ISO 320

### DIMENSIONS [mm]

H	W	D	F	H1	A	B	C
1425	902	736	540	270	350	412	334

### PERFORMANCE CURVES

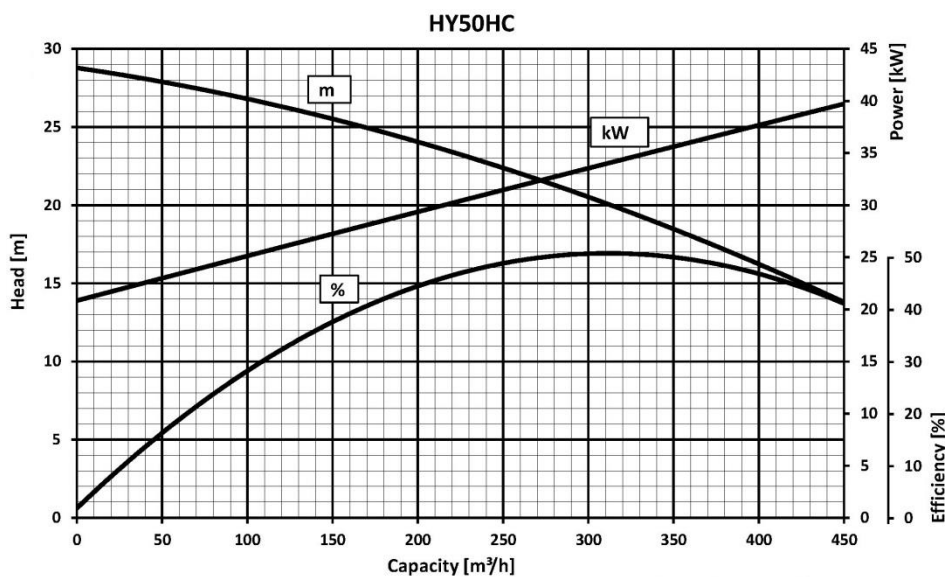

We reserve the right to make changes without notice

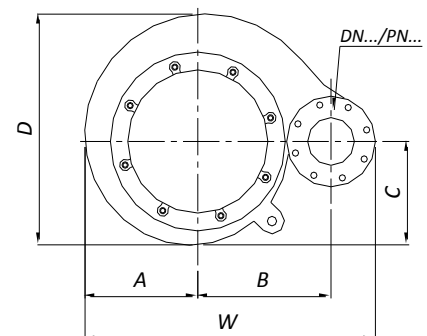
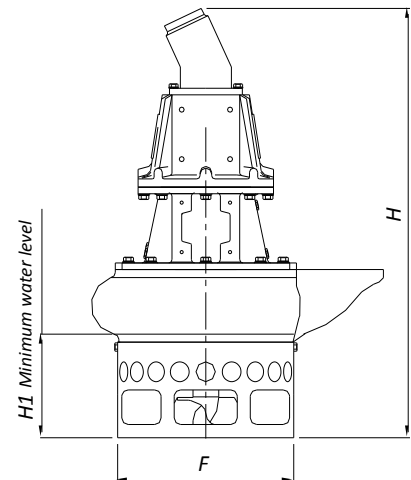

# HY50HC

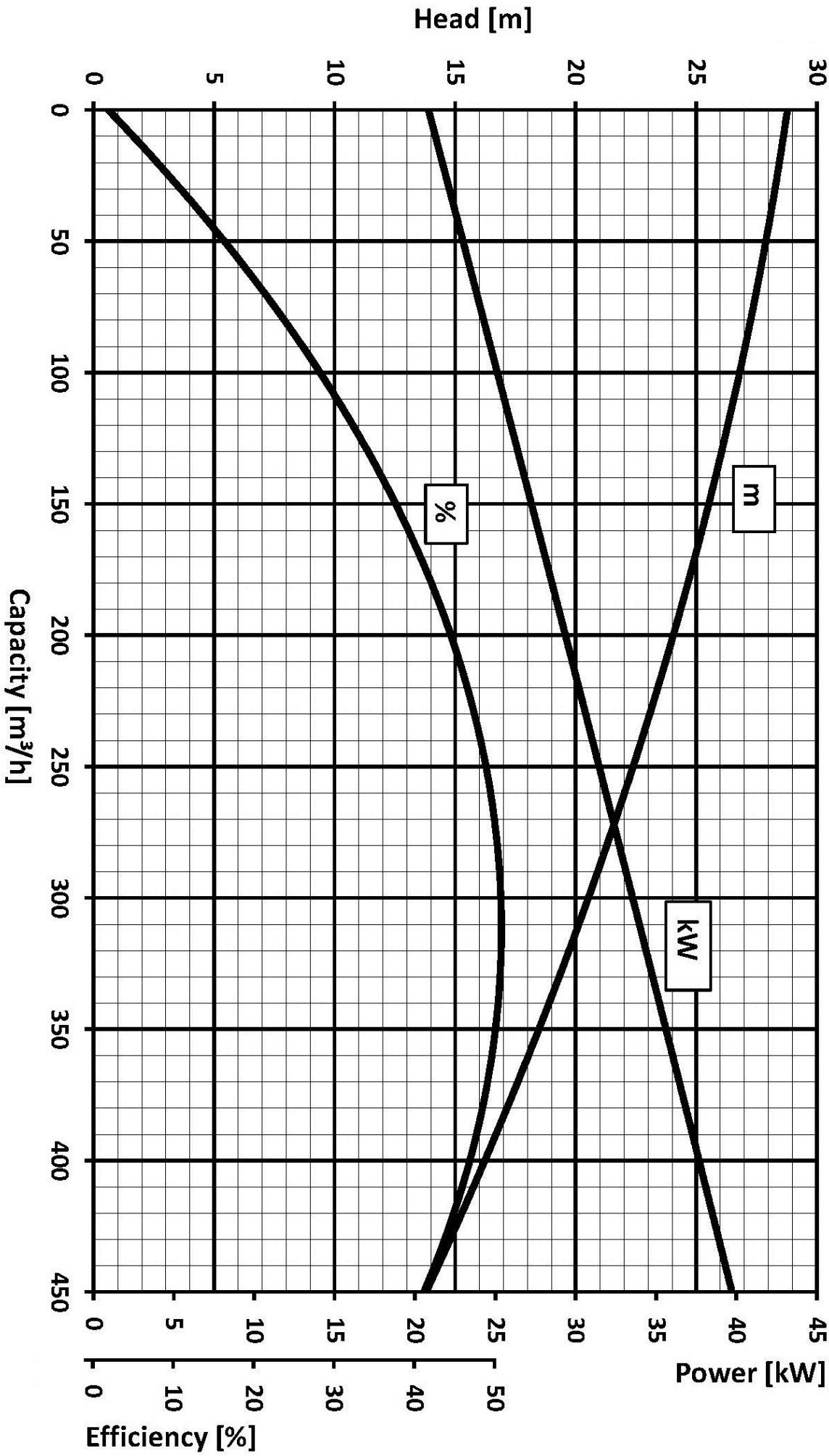

We reserve the right to make changes without notice